

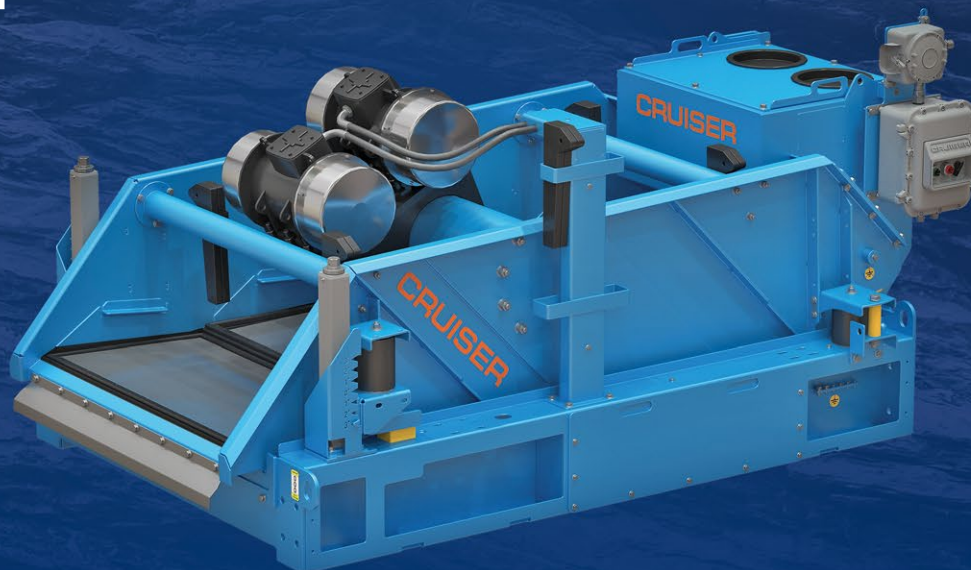

NEFTEKAMSK MACHINERY PLANT  
OF SPECIAL EQUIPMENT



SHALE SHAKER

**CRUISER**

**MK 700-1-04-1-UKhL3.1-40**

**CRUISER MK 700-X-XX-X-XXXX-X**

- SHALE SHAKER MODIFICATION
- CLIMATIC CATEGORY AS PER GOST STANDARD 15150-69
- TYPICAL SIZE OF SCREEN PANELS (1 – 1165x584 mm, 2 – 1181x712 mm, 3 – 1200x610 mm)
- TOTAL QUANTITY OF SCREEN PANELS
- QUANTITY OF DECKS (TIERS) OF SCREEN PANELS
- MANUFACTURER'S BASIC DESIGNATION OF SHALE SHAKERS
- MANUFACTURER'S TRADING MARK

#### PURPOSE

CRUISER shale shakers are designed for the primary removal of solids (sludge) from water-based or hydrocarbon-based drilling mud in mud cleaning systems for drilling oil and gas wells.

#### OPERATING MODES AND PERFORMANCE

Two types of oscillations are implemented on shale shakers: linear and elliptical. Depending on this, uniform or maximum efficient transportation of sludge is carried out.

#### DESIGN

All-welded vibration frame. Reliable and easily removable wedge fastening of screen panels. Reinforced jacks for adjusting the angle of inclination.

#### RELIABILITY AND OPERATING CONDITIONS

High reliability vibration motors with low noise levels. Shale shakers of own production of increased service life. Durable polyurethane screen panel seals. Vibrating frame springs are made of high-strength steel.

#### CORROSION PROTECTION

The working part of the vibrating frame is made of stainless steel. The design has a 3-layer coating of premium class enamel with increased durability.

#### SAFETY

All electrical equipment is explosion-proof. Explosion protection grade is IIGbcIIIBT4.

19 Magistralnaya St., Neftekamsk, Republic of Bashkortostan, 452683, Russia

Tel. +7 (34783) 2-02-02, 2-00-13, 7-02-39 | [www.nkmzst.ru](http://www.nkmzst.ru), [st@nkmz.ru](mailto:st@nkmz.ru)

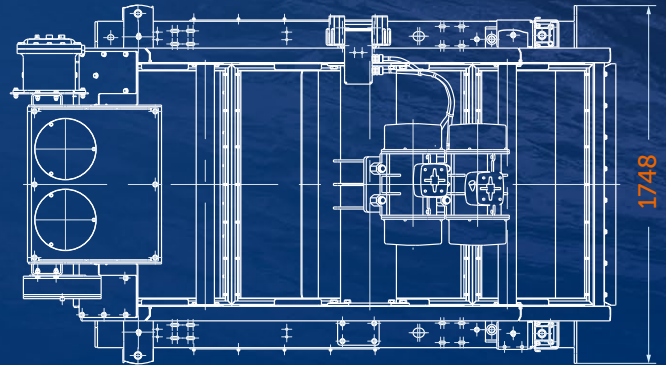
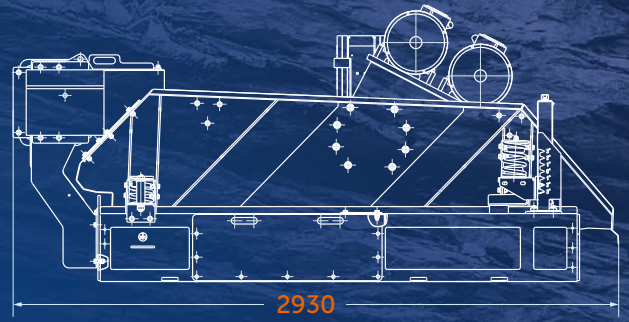
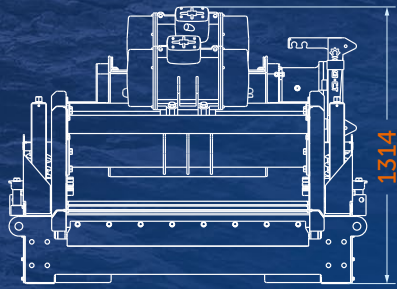

SHALE SHAKER

**CRUISER**

**MK 700-1-04-1-UKhL3.1-40**

## TECHNICAL SPECIFICATIONS

Description		Value
G overload factor		
- Linear		6 – 7.5
- Elliptical	G	5 – 6.5
Deck number	pcs	1
Screen amount	pcs	4
Total screen area	m <sup>2</sup>	2.73
Screen non-blanked area	m <sup>2</sup>	2.37
Screen panel sizes: length x width x height	mm	1165 x 584 x 40
Maximum throughput when drilling on water	l/s	38
Angle inclination adjustment possibility	degrees	+3, -3
Overflow height, max	mm	750
Receiver type		Overflow
Vibration motor number		2
One vibraton motor power	kW	2.3
Vibraton motor rotation frequency	rpm	1500
Voltage	V	380
Current frequency	Hz	50
Overall sizes, max: length x width x height	mm	2930 x 1748 x 1314
Mass, max	kg	1594

In connection with continuous shale shaker improvement work in order to increase reliability and performance, changes may be made to the design that are not stated in this description.



**Manufacturer: NKMZ-ST, Ltd.**

19 Magistralnaya St., Neftekamsk, Republic of Bashkortostan, 452683, Russia  
Tel. +7 (34783) 2-02-02, 2-00-13, 7-02-39 | [www.nkmzst.ru](http://www.nkmzst.ru), [st@nkmz.ru](mailto:st@nkmz.ru)