

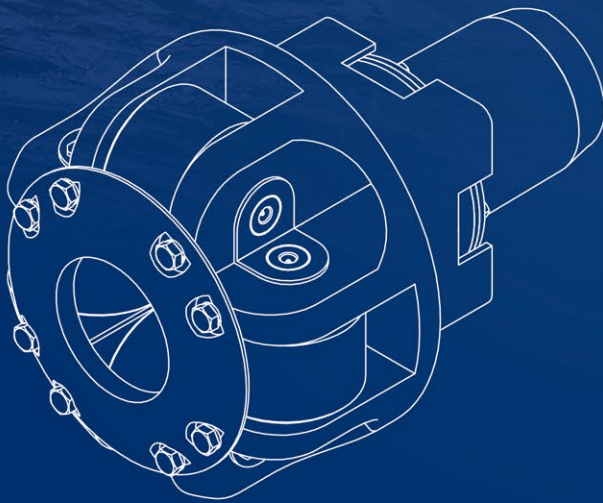

NEFTEKAMSK MACHINERY PLANT  
OF SPECIAL EQUIPMENT



## ROLLER KELLY BUSHING MK 200

### DESIGNATION

Roller kelly bushing is designed for torque transmission from rotary table to kelly bar.

### APPLICATION

Kelly bushing can be used with different unit sizes of kelly bars.

### CONSTRUCTION

Wear-resistant alloy steel is used in manufacturing of rollers.

Rollers have sleeve bearings and high tenacity synthetic material plates which ensure a longer operating life comparing to usual bearing parts, thus jamming of rollers is impossible.

Increased torque moment comparing to the Russian analogues.

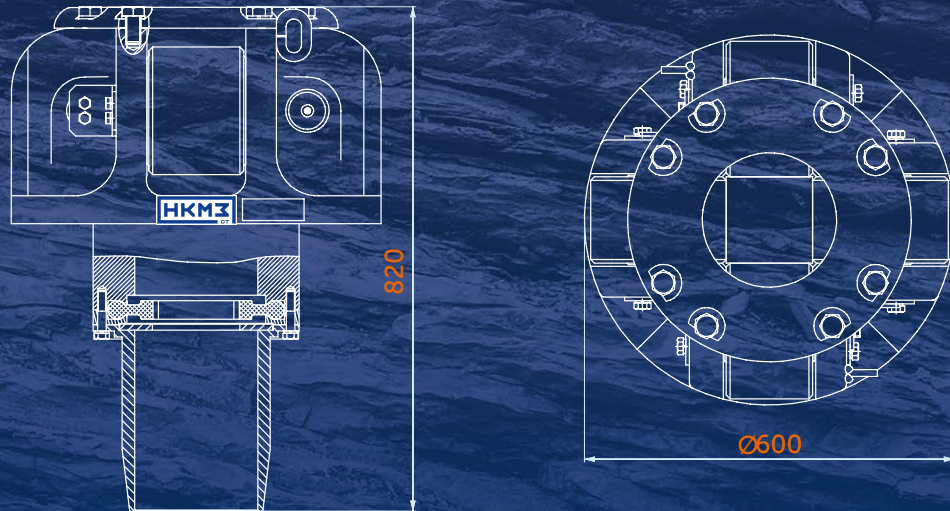

## ROLLER KELLY BUSHING MK200

### TECHNICAL SPECIFICATIONS

| Designation                      |        | Value                           |
|----------------------------------|--------|---------------------------------|
| Roller insert marking            |        | MK200.00.00.000-20              |
| Nominal header pipe size         | mm     | 80, 89, 108, 112, 133, 140, 155 |
| Torque                           | kN x m | 50                              |
| Overall dimensions, no more than | mm     | Ø 600 x 832                     |
| Weight, no more than             | kg     | 640                             |

### DIMENSIONS AND WEIGHT OF ROLLERS ASSEMBLY WITH BUSHING

| Square kelly, mm | Designation                               | Overall dimensions<br>(diameter x length), mm | 1 roller mass, kg |
|------------------|---|---|-------------------|
| 140              | MK 200.01.00.000-10<br>Roller assembly    | Ø 207 x 154                                   | 31.2              |
| 155              | MK 200.01.00.000-10-01<br>Roller assembly | Ø 195 x 154                                   | 25.7              |
| 89               | MK 200.01.00.000-10-02<br>Roller assembly | Ø 257 x 154                                   | 41.9              |
| 133              | MK 200.01.00.000-10-03<br>Roller assembly | Ø 214 x 154                                   | 33.6              |
| 80               | MK 200.01.00.000-10-04<br>Roller assembly | Ø 267.5 x 154                                 | 42.35             |
| 108              | MK 200.01.00.000-10-05<br>Roller assembly | Ø 237 x 154                                   | 41.2              |
| 112              | MK 200.01.00.000-10-06<br>Roller assembly | Ø 233 x 154                                   | 40.0              |

In connection with the constant work to improve the bushing in order to increase reliability and performance, design changes may be made that are not reflected in this description.



**Manufacturer: NKMZ-ST, Ltd.**

19 Magistralnaya St., Neftekamsk, Republic of Bashkortostan, 452683, Russia  
Tel. +7 (34783) 2-02-02, 2-00-13, 7-02-39 | [www.nkmzst.ru](http://www.nkmzst.ru), [st@nkmz.ru](mailto:st@nkmz.ru)