

Assembly Hoist PM-6.3 Hydro Burlak 63 Hydro with Bulldozing Kit

Assembly hoist PM-6.3 hydro with the hydraulic drive of boom pitch and round trip hook assembly is designed for materials-handling mechanization at mounting and dismounting of drilling and oilfield equipment and shifting of loads on a hook within the erecting site, as well as for operations from stripping to the development of batt, arenaceous limestone and sandy cobble.

The basis for transport, installation and load-carrying of the assembly hoist can be a bulldozer B- 10M or other types of bulldozers. The boom in its bare bones basic consists of two sections – lower and upper parts, the maximum boom outreach is 6 m.

One can complete the assembly hoist with the boom with an insert. The maximum boom outreach with the insert is 9 m and its carrying capacity is 5 t.

Specifications

Assembly hoist type	Boom, tractor, nonrotative, with tiltable boom
Assembly hoist installation and power base	Bulldozer B10M
Engine power, kW (h.p.)	132 (180) - engine D180, 176 (240) - engine YaMZ-238
Boom length, m	6.7
Boom outreach from the axis of driving sprocket, m:	
min.	2.5
max.	6.3
Load carrying capacity, max., (kN)	6.3 (63)
Load moment, t x m	15.75
Hook lifting height, m	6.3
Hook lifting speed, max., m/min	16.8
Hoist speed control	Soft, continuous, with proportional hydraulic control valve
Assembly hoist traveling speed, km/h, max.	
- with load	3.5
- without load	4.9
Winch	Double-stage planetary, with radial grooving on the drum and a holddown roll
Number of winches, pcs.	2
Drum diameter, mm	320
Line-carrying capacity of the drum, m	35
Winch brake	Multidisk frictional with selfoperative hydraulic and backup manual releasing of brake
Rope diameter, mm	14.0
Winch drive motor	310.3.56
Pump	NSh100
Nominal pressure in the hydraulic system, MPa	16
Boom sheave block rate	5
Load sheave block rate	4
Diameter of traction blocks on depressions, mm	270
Safety devices:	
Load limiter	OGM-240-32

Hook lifting height limiter

Kickout device

Boom outreach limiter

Kickout device

Safety devices and lighting power supply

On-board power network of tractor, U=24 V

Overall dimensions in transit condition with folded boom

length, mm

8700

height, mm

3600

width, mm

3440

Mass (max.), t

22.5

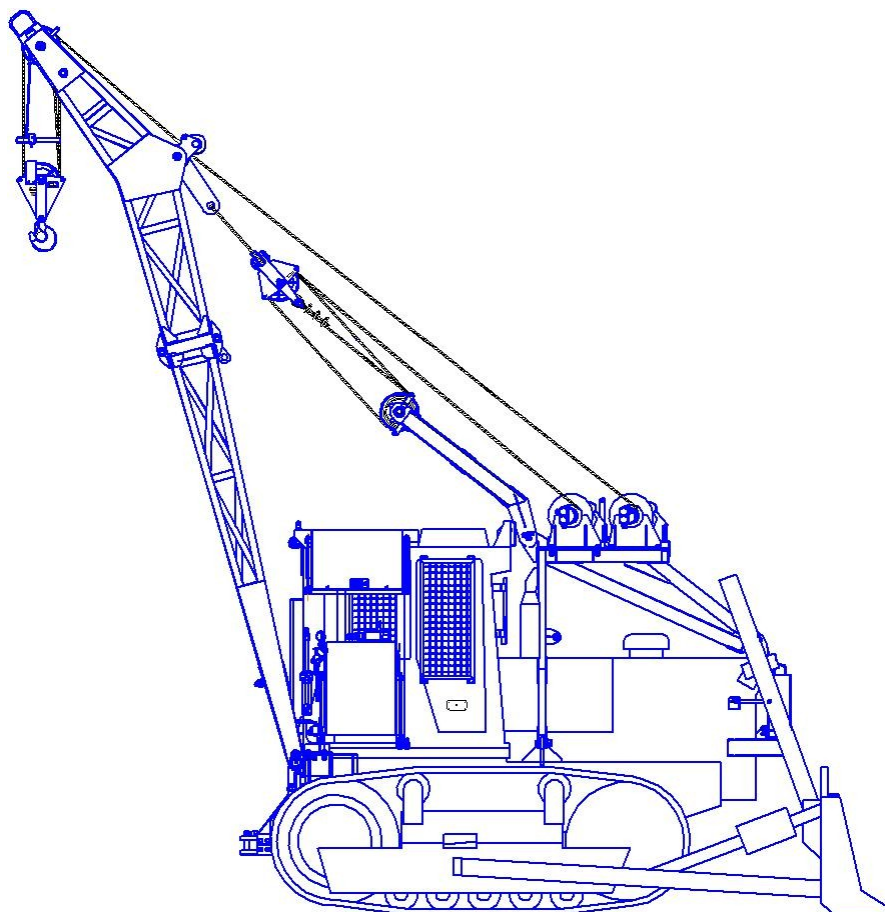



Manufacturer: NKMZ-ST Ltd.
19, Magistralnaya st., Neftekamsk
Republic of Bashkortostan
Russian Federation 452683
Tel: +7(34783)2-02-02, 2-00-13.
www.nkmzst.ru, st@nkmz.ru